

Auto Test®

Bluetooth Printer



The Auto Test Bluetooth Printer is compatible for use with the AutoStop Mini, Workshop Pro and the Auto Test Suspension Meter.



DECLARATION OF CONFORMITY

We, AutoTest Products Pty Ltd. declare under our sole responsibility that the product AutoTest Bluetooth Printer is in conformity with the provisions of the following Council Directive: 1999/5/EC.

A copy of the Declaration of Conformity is available from <http://www.autotest.net.au>

© AutoTest Products Pty Ltd (AutoTest) [2024].

Copyright in the drawings, information and data recorded in this document (the information) is the property of AutoTest Products. This document and the information are solely for the use of the authorised recipient and this document may not be used, copied, or reproduced in whole or part for any purpose other than that for which it was supplied by AutoTest Products. AutoTest Products makes no representation, undertakes no duty, and accepts no responsibility to any third party who may use or rely upon this document or the information.

Under no circumstances shall AutoTest Products be responsible for any loss of data or income or any special, incidental, consequential or direct damages howsoever caused. The contents of this document are provided "as is". Except as required by applicable law, no warranties of any kind, either express or implied, including, but not limited to, the implied warranties of merchantability and fitness for a particular purpose, are made in relation to the accuracy, reliability or contents of this document. AutoTest Products reserves the right to revise this document or withdraw it at any time without prior notice.



1.1 APPEARANCE

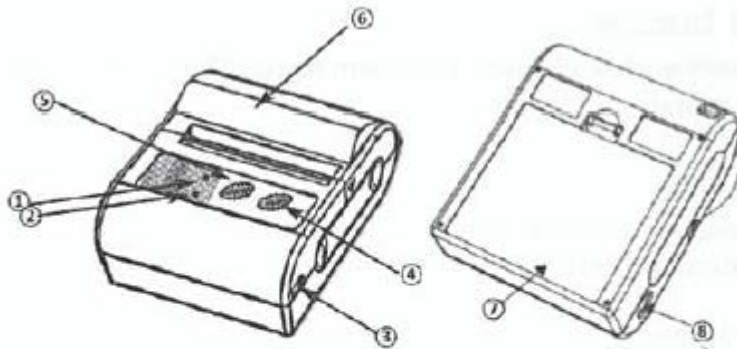

- 1. Power Indicator
- 2. Status Indicator
- 3. Power Input
- 4. FEED Button

- 5. Power On/Off
- 6. Top Cover
- 7. Li-ion Battery
- 8. UART Interface

1.2 ACCESSORIES

Standard Accessories



Li-ion Battery

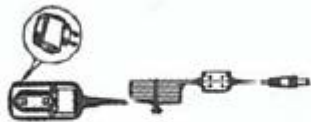

Power Adapter



Paper Roll



USB Cable

2. SPECIFICATIONS

Item		Parameter
Printing	Printing method	Thermal line printing
	Resolution	203dpi, 8dots/mm
	Printing speed	MAX.70mm/s
	Valid printing width	48mm
	Interface	Bluetooth, RS-232, USB (optional)
Power saving	Sleep mode	YES
Character Set	Font	ASCII:8x16,9x24,12x24; Multiple code pages support
Barcode Symbolologies	1D	UPC-A, UPC-E, EAN8, EAN13, CODE39, ITF, CODEBAR, CODE128, CODE93
	2D	QR code
Graphics		Support bitmap printing with different density and user defined bitmap printing. (Max. 40K per bitmap, and Max. 64K for total)
Detection	Sensors	Paper out detection
LED indicator	Power indicator	Red
	Error indicator	Blue
Charging	Power charger	12V 0.5A
	Battery	1500mAh 7.4V rechargeable Li-ion battery
Paper	Paper type	Thermal paper
	Recommended paper	FD210, PD150R, PD160R (OJI Paper CO., LTD.)
	Paper width	58mm
	Paper thickness	≤0.1mm
	Paper roller diameter	≤40mm
	Paper loading	Easy loading mechanism
Physical characteristics	Working operating temp.	-5°C ~50°C, 25% ~80%RH
	Storage condition	-40°C ~60°C, ≤ 93%RH (40°C)
	Dimension	102.5*75*45mm
	Weight	279g (without paper roll)
Reliability	TPH	50km (not more than 12.5% printing density)/100 million pulses
Software	Emulation	ESC/POS
	Driver	Windows XP/Vista/Win7/Win8/Win10

3.1 PREPARATION BEFORE USING

3.1.1 Li-ion Battery Installation

- 1) Place the battery in the battery slot, paying careful attention to the correct positive and negative terminals. (Refer to picture)
- 2) Close the battery case.

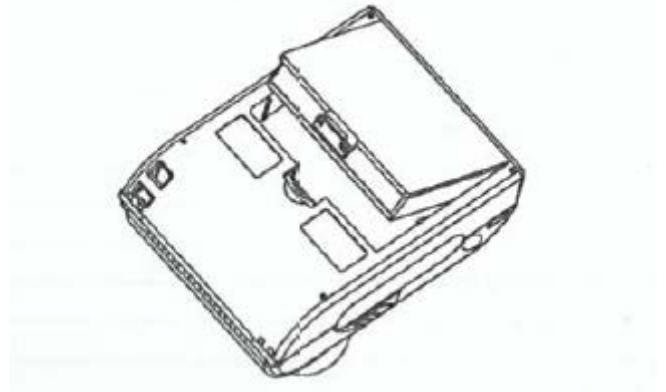

3.1.2 Loading Paper

Operation Methods:

- 1) Use two fingers to press the place indicated in the picture and open the top cover.
- 2) Put the paper into the paper case, paying attention to the direction of the paper. If loaded in reverse, it will not print.
- 3) Pull paper out of the paper case.
- 4) Make sure the paper is in the center before closing the top cover.

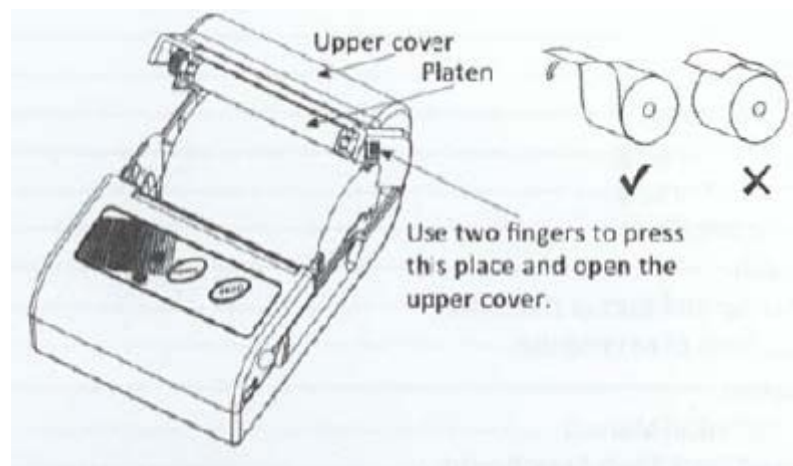

3.2 Basic Functions

3.2.1 Power On

To turn on the printer, press and hold the 【 POWER 】 button down for 2-3 seconds, or until the power indicator light turns red.

Note: When the battery is almost flat, the power indicator blinks in a blue colour. In this case, you must charge the battery. See more information about the method of charging the battery in 3.2.7 Battery Charging.

3.2.2 Power Off

The printer is turned off by holding down the 【 POWER 】 button for 2-3 seconds. All of the indicator lights will switch off when the printer is off.

3.2.3 Self-test

The self-test indicates the printer's current settings, status and whether the printer has any problems. Hold down the 【FEED】 button while pressing the 【POWER】 button for 2-3 seconds or until the self-test begins. The printer is ready to receive data as soon as it completes the self-test.

3.2.4 Feeding Paper

Users can use the 【FEED】 button to feed paper manually. The printer will stop feeding when it reaches its maximum feeding distance.

Note: The roll of paper needs to be rolled straight otherwise the paper will jam and will not print. To straighten the paper roll, take out the roll and straighten in your hands.

Store paper rolls away from high temperature environments and sunlight.

3.2.5 Standby/Sleep

The printer has auto-sleep and auto-wake up functions to help save the battery power.

If data is sent during the pre-set standby time, data will not be printed. When no data is sent to the printer for a period of time, it will automatically enter the standby mode. When the printer enters the standby mode, the power indicator will turn red and the power consumption will significantly decrease, but will have no impact on the printer working. The printer will automatically wake up when receiving printing data without any extra operation.

If the printer enters auto standby mode during the pre-set auto sleep time and it receives no data and has no job sent to it, the printer will automatically turn off completely. Users will have to turn on the printer again if they want to use it.

While the printer has the auto standby and auto sleep function to save the battery power, please turn off the printer when it is not in use, which is the optimal way to save battery power.

3.2.6 No Paper Warning

The printer has a paper sensor to detect paper. If the printer has no paper, the function indicator and power indicator will flash slowly. If the paper is used up while the printer is doing the printing job, the printer will continue to print the unfinished printing job when a new paper roll is loaded.

3.2.7 Low Battery Charging

When the Li-ion battery runs out of power, the blue LED indicator will flash slowly. It will turn off automatically after a period of time if you try to continue printing. If you want to continue printing, please charge it.

CHARGING METHOD:

1) Connect the USB cable to the power connector of the printer.

2) Plug the power charger into an electrical outlet.

Power-ON charging: LED light will always indicate blue colour and will switch off once fully charged.

Power-OFF charging: LED light will keep blinking blue and will depend on the current state of the printer when fully charged.

Note: Please use the original battery and power charger, otherwise it may cause printer damage and battery leakage, fire and/or explosion.

YES – You can use the printer while charging!

3.3 Bluetooth

The *AutoTest* Bluetooth Printer is compatible for use with the *AutoStop* Mini, *Workshop Pro* and the *AutoTest* Suspension Meter.

Most mobiles, Laptops and other information terminals with a Bluetooth interface can operate the printer.

Instructions:

1. Power on the printer.
2. On the *Workshop Pro* device, search for other Bluetooth devices. For *AutoStop* Mini and the *Suspension Meter* it connects automatically
3. In the list of Bluetooth devices, choose MTP58BN.
4. Enter password "0000".
5. Finish matching.

Note: When pairing, do not have more than one printer on at once, otherwise it may not be able to figure out which one it needs to pair with.

3.4 LED Indicator and Buzzer Definition

There is one buzzer and two LED indicators to indicate the printer status. The LED indicators show current status and the buzzer indicates the change of status.

Status Indicator (blue)	Power Indicator (red)	Status
Flashing	OFF	Power-on charging
ON	OFF	Power-off charging
Flash	OFF	Battery low
Depends on the current state of the printer		Power-on charging, battery full
OFF	OFF	Power-off charging, battery full
OFF	ON	Power on
Flashing	Flashing	Paper end
OFF	Flashing	Standby

Buzzer	Status
Once	Power on
Twice	Power off
Once	Press 【FEED】 button
Three times	Power-on charging, battery full
	Enter to the parameter setting mode
Four times	Download the Font library

4. TROUBLESHOOTING

For other problems, contact *AutoTest* Products. Repairs should only be carried out by *AutoTest* Products Pty Ltd or by an Authorised Service Centre in order to ensure the product retains its calibration.

5. WARRANTY

To ensure prompt warranty service should it be required, please complete warranty registration form, and return to *AutoTest* Products Pty Ltd within 10 days of purchase of the product. *AutoTest* Products or an Authorised Service Centre warrants this product against defects in material and workmanship for a period of 12 months from the original date of purchase. This warranty applies only to products and components supplied by *AutoTest* Products which can be identified by the trade name or logo affixed to them or by other documents. *AutoTest* Products does not warrant any products not supplied by *AutoTest* Products. During the warranty period, *AutoTest* Products or an Authorised Service Centre will repair (or at its option replace), any defective component(s) without charge for labour, provided the product is returned in its original or suitable equivalent container, freight prepaid, to an authorised *AutoTest* Service Centre. Transit insurance and return freight will be at the owner's expense.

In order to obtain calibration, warranty or non-warranty service, ship the product, freight and insurance prepaid to your nearest *AutoTest* Service Centre. Attach to the product your name, address, contact numbers, description of the problem and if a warranty claim, proof of purchase (dated sales receipt or invoice).

AutoTest Products or an Authorised *AutoTest* Service Centre reserves the right to refuse warranty repair if accident, abuse, misuse or misapplication has damaged the product in transit or as a result of service or modifications by other than an Authorised Service Centre, nor are any other warranties expressed or implied, including any regarding merchantability or fitness for any other particular purpose. *AutoTest* Products or an Authorised Service Centre is not responsible for incidental or consequential damages resulting from the breach of any express or implied warranty, including damage to property and, to the extent permitted by law, damages for personal injury.

NOTES:

Copyright 2024 AutoTest Products Pty Ltd ABN 47 005 712 005.

® denotes a trademark owned by AutoTest Products Pty Ltd ABN 47 005 712 005.



AUTOTEST Products Pty Ltd

69 Parsons St Kensington VIC 3031 Australia

Phone: (+61 3) 8840 3000

Service: (+61 3) 8840 3016 service@autotest.net.au

Sales: (+61 3) 8840 3017 sales@autotest.net.au

www.autotest.net.au